

# Hand pallet truck scale

Application for use in the logistics of receiving, transmitting and recording of goods and in the agricultural sector to record harvests.

De PTI-Supply-Chain is equipped with weighing-unit, labelprinter, barcode scanner and Wifi.

- count articles of the same type (pieces, liters)
- scan pallets by the scanner
- look up customers in the customer database and scan them
- search products in the products database and scan them
- print stickers with barcode and weight, sender, consignee, lot number, pallet location, etc.



Option: indicator HP-Ultra



## model PTI-Supply-Chain

### Properties

- standard equipped with weight indicator HP-Touch in plastic housing
- capacity 2000 kg
- dual range or triple range division (n.f.l.t.)
- n.f.l.t. (not for legal trade) or CE verified (see table below)
- painted construction, mechanical parts stove enamelled
- fork dim. 1150 x 550 x 85 mm
- own weight about 125 kg
- 4 stainless steel IP68 shear-beam load cells
- steering wheels and double loading rollers with a polyurethane coating
- bearing structure in extra thick sheet steel and oven-fire painted interior construction
- including **label printer**, 58 mm width, 24/40 columns, integrated in column below the indicator; prints ia product name, number, weight and barcode or logo
- provided with **extra weigh platter**, stainless steel 200 x 200 mm for the determination of reference values, and counting of small articles of the same type
- HP-Touch screen indicator in plastic housing, IP65, backlit graphic display with touch screen technology, dim. 120x90mm (l x h); multilanguage software; 1-key waterproof keyboard
- power: internal rechargeable battery; incl. 230V charger; the operating time is of about 10 hours of continuous use, or 24/24h with second optional rechargeable battery.
- full duplex RS-232C-port for receipt- or label printer
- full duplex RS-232C-port with RJ-connector for fast communication with PC
- 3 relay outputs 0.5A 48VAC (NO or NC-contacts)
- 2 optoisolated inputs functioning as remote control keys
- date/time function; IR-input for remote control date / time function; IR input for remote control
- **comprehensive counting function**: pieces, liters, etc., charging / discharging, subtraction, residue-counting, data entry protocol, database for 1000 articles, 200 customers and 300 tares, 4 totals, barcode scanning with article activation

### Options i.a.

- equipped with indicator HP-Ultra
- IR remote control
- alibi memory, max. 120.000 weighings
- wireless connection to PC/printer
- wireless interface t.t.b.o. indicator and PC/printer, incl. RS-232, max. distance indoor 70 m, outdoor 150 m.
- serial interface for connection to PC-keyboard / scanner
- Industrial hand scanner

type	PTI-Supply-Chain	PTIM- Supply-Chain
version	comprehensive totalization	
capacity	2000 kg	2000 kg
division	–	1 kg
division 1* 0 - 1000 kg	0.2 kg	–
division 2* 500 -1000 kg	0.5 kg	–
division 3* 1000-2000 kg	1 kg	–
CE-verified	–	<b>M</b>

\* With triple range division reading within the first part (1) of the capacity is 2x more accurate than within the second part (2); within the second part of the capacity reading is again 2x more accurate than within third part (3).

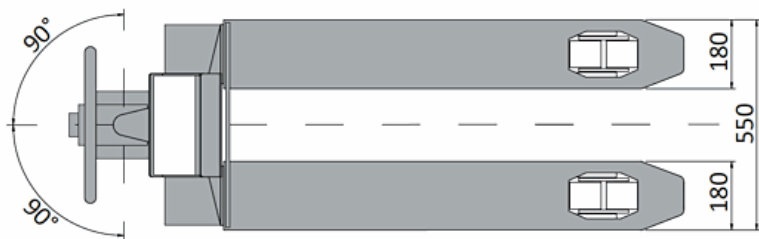
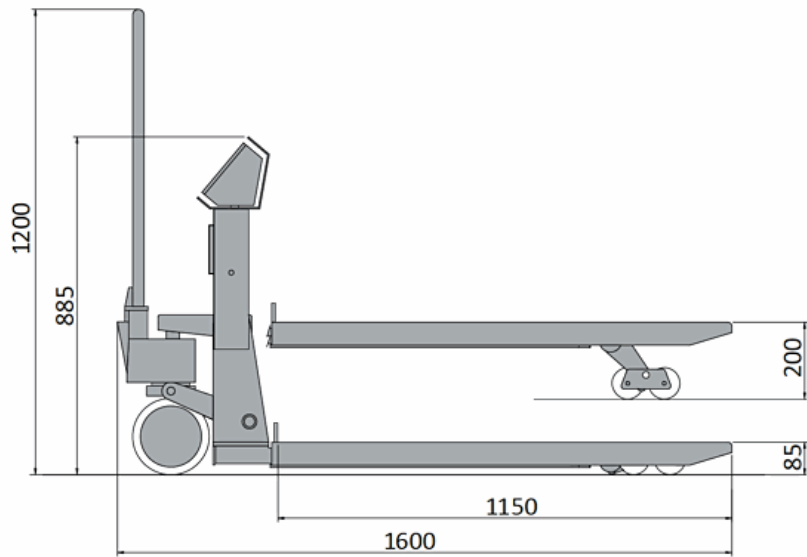

dimensions in mm

